



Flanged End Floating Ball Valves

Ideal Design for Process and Petrochemical Applications



Size - 3" F300

FULL-FLO SERIES

Models

F150 Class 150 / F300 Class 300

Full Port: 1/2" - 12"

Standard Steam Working Pressure:
150 SWP, optional 300 psig



Size - 6" SF150

UNI-FLO SERIES

Models

SF150 Class 150 / SF300 Class 300

Reduced Port: 1"-12"

Standard Steam Working Pressure:
150 SWP, optional 300 psig

Design Features

- Floating Ball Design
- Protected Seat Design
- O-Ring Backed Seat
- Fire Safe Designed to API 607-5
- Spiral Wound Body Gasket with Secondary Metal to Metal Seal
- Open and Close Locking Device for Position Safety Lockout
- O-Ring Reinforced Stem Packing
- Cryogenic Design • Option
- I-SO-Mount, Actuator Mounting Pad Standard
- Super-Tek Seating
- Live Loaded Stem Design
- Anti-Static Grounding Device
- Secondary Containment Option
- Flatted Shaft - Positive Flow Indication
- Ball Cavity Relief
- V-Ball Control • Option
- **Metal Seats Option, Class V & VI**

Valves for other flanged standards, such as DIN, JIS, BS, NFE and GB are also available.

Website: www.flotite.com

Design Specifications

Standards of Compliance

Travel stop incorporates Locking Device, can also be used as actuator lock out device

Stop housing separates valve stop from packing gland, eliminates stop plate impacting on packing gland

I-SO Mount Actuator Mounting, 4 bolt design eliminates torsional stress, actuator can be removed while valve is under full pressure

Recessed groove enables top flange to be adapted with a secondary containment bonnet for fugitive emission, cryogenic service and other critical applications

Pocketed and recessed seats with secondary metal backup seal.

O-Ring encapsulated in the back of the seat, a unique "flex-load" energized seat design

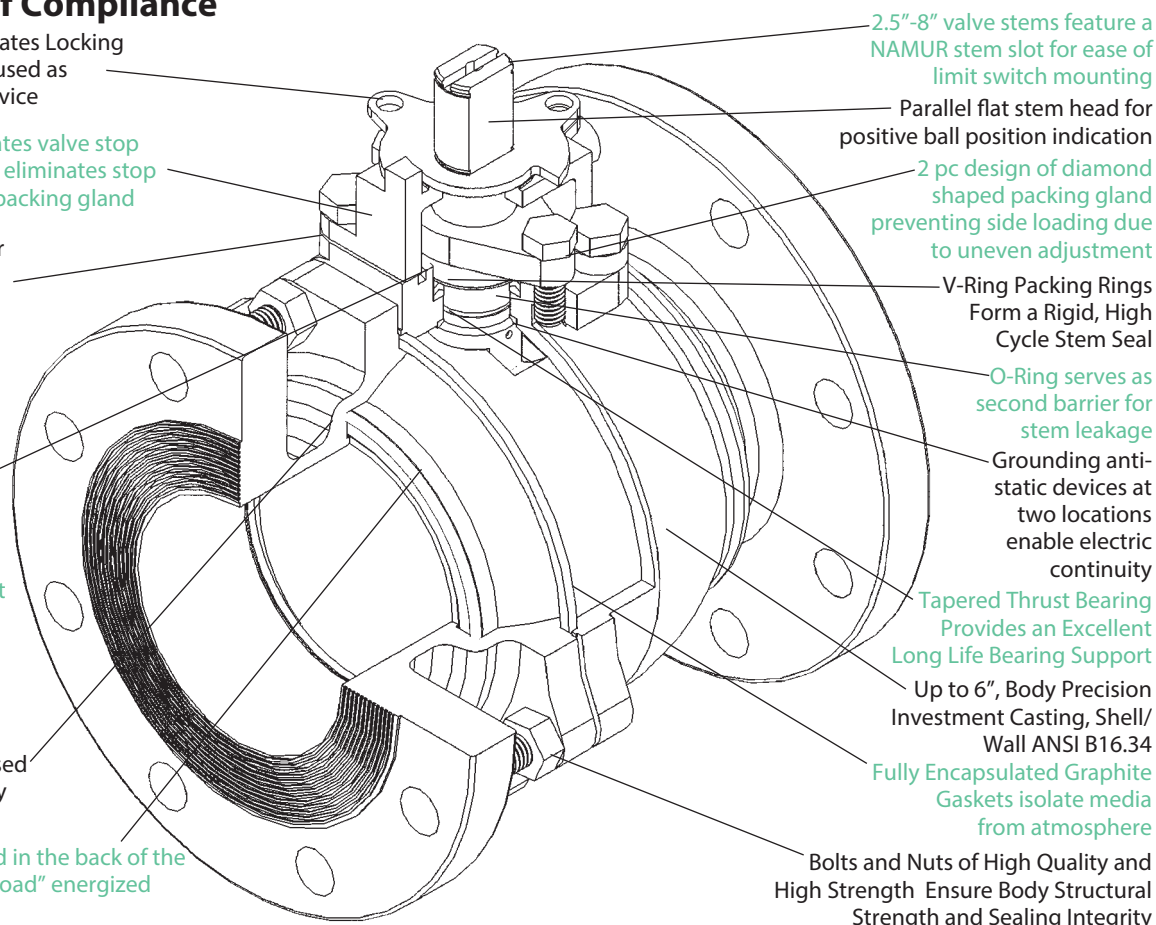

2.5"-8" valve stems feature a NAMUR stem slot for ease of limit switch mounting

Parallel flat stem head for positive ball position indication

2 pc design of diamond shaped packing gland preventing side loading due to uneven adjustment

V-Ring Packing Rings Form a Rigid, High Cycle Stem Seal

O-Ring serves as second barrier for stem leakage

Grounding anti-static devices at two locations enable electric continuity

Tapered Thrust Bearing Provides an Excellent Long Life Bearing Support

Up to 6", Body Precision Investment Casting, Shell/Wall ANSI B16.34

Fully Encapsulated Graphite Gaskets isolate media from atmosphere

Bolts and Nuts of High Quality and High Strength Ensure Body Structural Strength and Sealing Integrity

Optional live-loaded packing with belleville springs

Flotite's Flanged series valves with graphite stem packing meet the highest fire safety standards under extreme conditions. In the event of a fire, after heat destroys the primary resilient seat, the ball makes contact with the secondary metal seat, forming a secure seal. The body seal, composed of stainless steel and graphite wound into a spiral, prevents external leakage. The graphite stem rings prevent stem leakage.

Fire Safe: API607-4 & 5 Certified

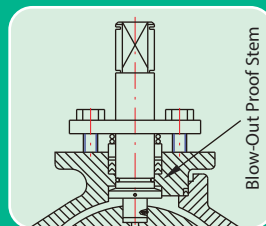
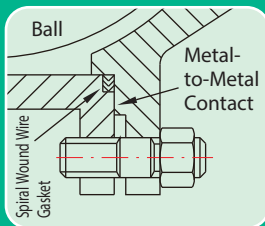
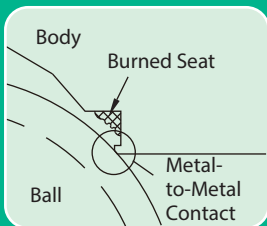

Standards and Specifications

Valves covered in this bulletin are available to conform to the following industry standards and specifications

All valves are manufactured to ISO 9001 quality standards.

WW-V-35C	Federal Specification: Valve, Ball
ANSI/ASME B16.10	Face-to-Face / End-to-End Dimensions of Ferrous Valves
ANSI/ASME B16.5	Steel Pipe Flanges and Flange Fittings
ANSI/ASME B16.34	Steel Valves - Flanged and Butt-welded End
ANSI/ASME B31.1	Power Piping
ANSI/ASME B31.3	Chemical Plant & Petroleum Refinery Piping
ANSI/FCI 70-2-1976	For Control Valve Leakage
BS 6755, Part 2	Testing of Valves - Specification for Fire Type Testing
ISO 5752:1982	Metal Valves for use in Flanged Piping Systems
ISA 75.02	Valve Sizing Coefficient Cv, Piping Geometry Factor Fp and Pressure Drop Limitation XT
ISA 575.19	Hydrostatic Testing of Control Valves
ISO 5211	Dimensions for Attachment of Actuators/Gear Boxes to Valves (ISO Mounting)
MSS-SP-25	Standard Marking Systems for Valves
MSS-SP-55	Quality Standards for Steel Castings

MSS-SP-6	Standard Finishes for Contact Faces of Pipe Flanges and Connecting-End Flanges of Valves and Fittings
MSS-SP-44	Steel Pipe Line Flanges
MSS-SP-61	Pressure Testing of Steel Valves
MSS-SP-72	Flanged or Butt and Weld End Ball Valves Having Full or Reduced Bores for General Liquid and Gas Service
MSS-SP-96	Terminology for Valves and Fittings
NACE MR01-75	Sulfide Stress Cracking Resistant Materials for Oilfield Equipment.

Optional Standards & Specification

API 608	Metal Ball valves Used in On-Off Service that have Butt-welded or Flanged Ends for Size 1/2" NPS - 12" NPS
API 6D	Specifications for Pipeline Valves
API 598	Valve Inspection and Testing
MSS-SP-53	Quality Standard for Steel Casting and Forging for Valves, Flanges and Fittings and Other Piping Components-Magnetic Particle Examination Method
ISO 15848-1	Industrial valves - Measurement, test and qualification procedures for fugitive emissions

Bill of Materials / Full Port Valves

No.	Name	Stainless Steel	Carbon Steel
1	Body	ASTM A351 CF8M	ASTM A216 WCB
2	Cap	ASTM A351 CF8M	ASTM A216 WCB
3	Stem*	SS316	SS316 / SS304
4	Packing Follower	SS304	SS304
5	Belleville Washer	SS301	SS301
6	Lock Washer	SS304	SS304
7	Ball	SS316	SS316 / SS304
8	Seat	TFM	TFM
9	Gasket	RPTFE / Graphite	RPTFE / Graphite
10	Stem Packing	TFM / Graphite	TFM / Graphite
11	Packing Protector	50%PTFE+SS316	50%PTFE+SS316
12	Thrust Washer	25%Carbon+TFM	25%Carbon+TFM
13	Anti-Static	SS304	SS304
14	Valve Stop	SS304	SS304
15	Handle	SS304	SS304
16	Locking Device	SS304	SS304
17	Handle Sleeve	Plastic	Plastic
18	Thin Nut	SS304	SS304
19	Body Stud	ASTM A193 B8	ASTM A193 B7
20	Body Nut	ASTM A194 Gr.8	ASTM A194 2H
21	Bolt	SS304	SS304
22	O-Ring	Viton	Viton
23	Seat O-Ring	Viton	Viton

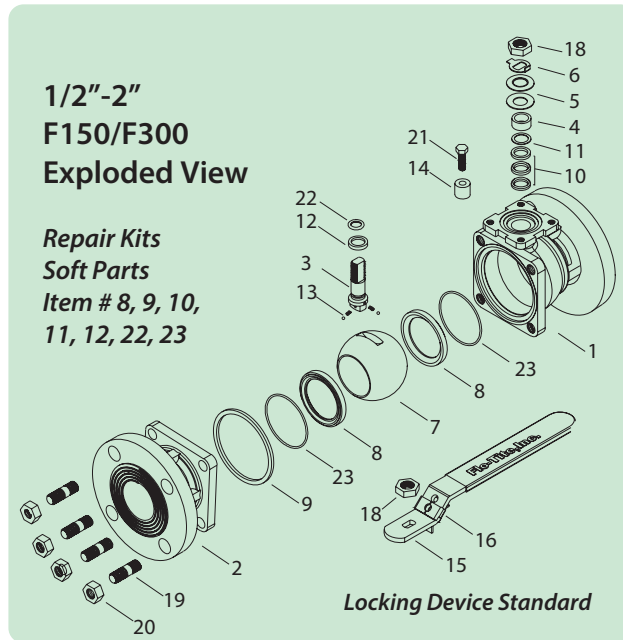

Bill of Materials

No.	Name	Stainless Steel	Carbon Steel
1	Body	ASTM A351 CF8M	ASTM A216 WCB
2	Cap	ASTM A351 CF8M	ASTM A216 WCB
3	Stem*	SS316	SS316 / SS304
4	Packing Gland	ASTM A351 CF8	ASTM A351 CF8
5	Packing Follower	SS304	SS304
6	Ball	SS316	SS316 / SS304
7	Seat	TFM	TFM
8	Stem Packing	TFM / Graphite	TFM / Graphite
9	Packing Protector	50%PTFE+SS316	50%PTFE+SS316
10	Gasket	RPTFE / Graphite	RPTFE / Graphite
11	Thrust Washer	25%Carbon+TFM	25%Carbon+TFM
12	O-Ring	Viton	Viton
13	Anti-Static	SS304	SS304
14	Travel Stopper	SS304	Steel
15	Snap Ring	Plated Steel	Plated Steel
16	Handle	Ductile Iron	Ductile Iron
17	Gland Bolt	SS304	Steel
18	Stop Housing	SS304	SS304
19	Housing Bolt	SS304	SS304
20	Body Stud	ASTM A193 B8	ASTM A193 B7
21	Body Nut	ASTM A194 Gr.8	ASTM A194 2H
22	Seat O-Ring	Viton	Viton
23	Set Screw	Steel	Steel

* Stem Optional Material 17-4PH

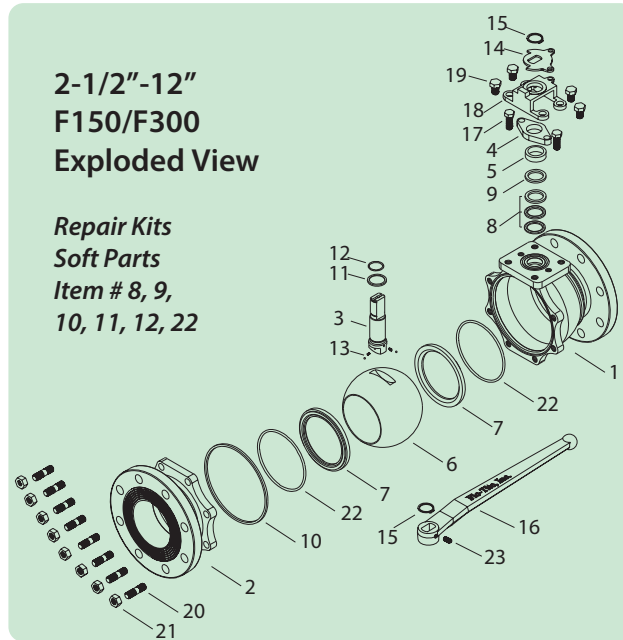

Optional live-loaded packing with belleville springs

Pressure Temperature Rating

These ratings are conservative guide for general service. Previous experience in process or new development may permit applications at ratings above those shown.

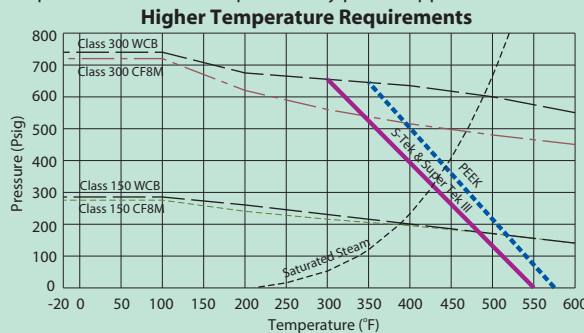
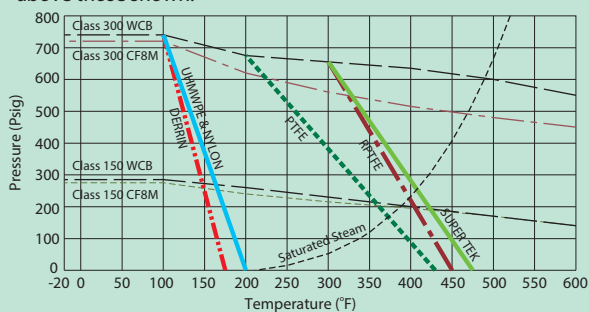

Saturated steam services above 150 psi use either Super Tek III or S-Tek. Saturated steam services above 250 psig use metal seats. Metal Seated Ball Valve will take full ANSI body metal material ratings.

Dimensions - Full Bore

Technical Submittal

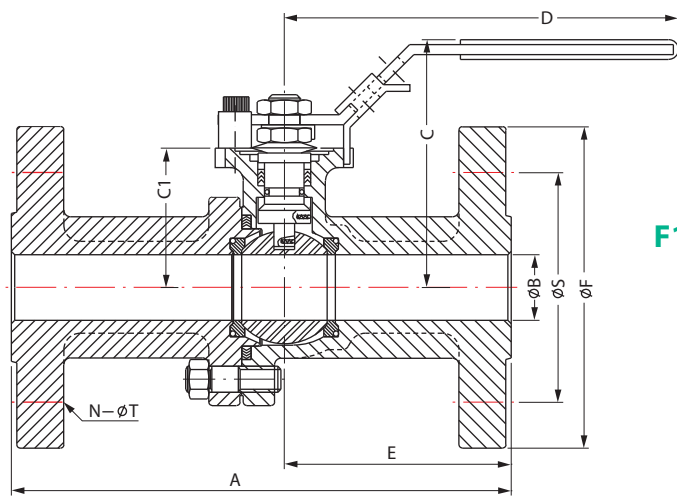

Size 1/2"-2"

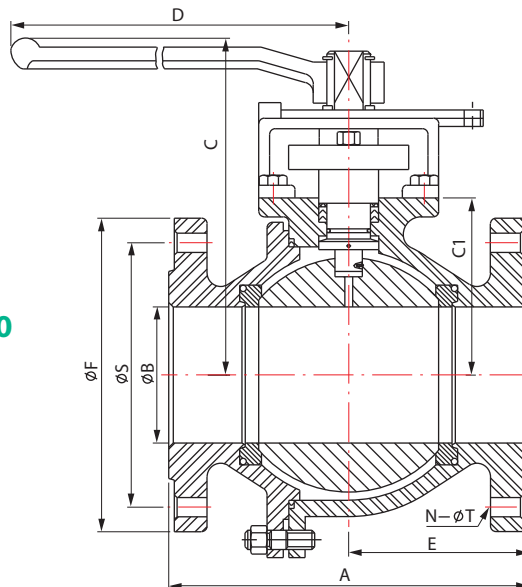

Size 2 1/2"- 12"

F150/F300 SERIES

Model F150 - ANSI Class 150

Size	A	B	C	C1	D	E	F	N	S	T	Cv	Torque in-lb	Est. Weight Lbs
1/2"	4.25	0.59	2.60	1.54	6.50	1.79	3.50	4	2.38	0.62	17	62	4
3/4"	4.62	0.79	2.91	1.70	6.50	2.01	3.88	4	2.75	0.62	43	90	5
1"	5.00	0.98	3.43	2.06	7.87	2.05	4.25	4	3.12	0.62	74	100	7.5
1 1/4"	5.50	1.26	3.62	2.35	7.87	2.45	4.62	4	3.50	0.62	192	240	13.5
1 1/2"	6.50	1.50	4.13	2.65	9.84	2.76	5.00	4	3.88	0.62	290	270	14.5
2"	7.00	1.97	4.53	2.90	10.4	3.07	6.00	4	4.75	0.62	410	360	21
2 1/2"	7.50	2.56	6.22	3.39	15.4	3.08	7.00	4	5.50	0.75	780	620	33.5
3"	8.00	3.00	6.54	3.67	15.4	3.74	7.50	4	6.00	0.75	1120	800	42.5
4"	9.00	4.00	7.20	4.40	15.4	4.47	9.00	8	7.50	0.75	1825	1700	62
6"	15.5	5.98	11.2	7.20	25.6	7.62	11.0	8	9.50	0.88	4700	4600	165
8"	18.0	7.87	11.6	7.60	37.4	8.35	13.5	8	11.75	0.88	10100	9900	262
10"	21.0	9.84	14.4	9.88	38.0	10.5	16.0	12	14.25	1.00	17500	17000	468
12"	24.0	11.8	16.1	11.5	38.0	12.0	19.0	12	17.0	1.00	22400	23000	714

Large sizes available in our trunnion series

Model F300 - ANSI Class 300

Size	A	B	C	C1	D	E	F	N	S	T	Cv	Torque in-lb	Est. Weight Lbs
1/2"	5.5	0.59	2.60	1.54	6.50	1.79	3.75	4	2.62	0.62	15	65	5
3/4"	6.00	0.79	2.91	1.70	6.50	2.01	4.62	4	3.25	0.75	40	95	7
1"	6.50	0.98	3.43	2.06	7.87	2.13	4.88	4	3.50	0.75	70	105	10
1 1/4"	7.00	1.26	3.62	2.35	7.87	2.45	5.25	4	3.88	0.75	189	252	C/F
1 1/2"	7.50	1.50	4.13	2.65	9.84	2.76	6.12	4	4.50	0.88	300	284	19
2"	8.50	1.97	4.53	2.90	10.4	3.07	6.50	8	5.00	0.75	430	378	25
2 1/2"	9.50	2.56	6.22	3.39	15.4	3.08	7.50	8	5.88	0.88	768	651	42
3"	11.12	3.00	6.54	3.67	15.4	3.74	8.25	8	6.62	0.88	1090	840	60
4"	12.0	4.00	7.20	4.40	15.4	4.47	10.0	8	7.88	0.88	1900	1785	93
6"	15.88	5.98	11.2	7.20	25.6	7.62	12.5	12	10.62	0.88	4800	4830	221
8"	19.75	7.87	11.6	7.60	37.4	8.35	15.0	12	13.0	1.00	10000	10395	371
10"	22.38	9.84	14.4	9.88	38.0	10.5	17.5	16	15.25	1.12	17350	17850	576
12"	25.50	11.8	16.1	11.5	38.0	12.0	20.5	16	17.75	1.25	21700	24150	C/F

All Valves are hydrostatically Pressure Tested (Shell) & Air Pressure Tested (seat) to the following:

Class 150:	Class 300:
Shell Test:	Shell Test:
450 psi for CS	1125 psi for CS
425 psi for SS	1100 psi for SS
Seat Test: 80 psi	Seat Test: 80 psi

Mounting Dimensions (F150/F300)

Size	d	K	L	M	P	W	ISO
1/2"~3/4"	1.65	0.31	0.55	0.250	0.37	#10-24UNC	F04
1"~1 1/4"	1.97	0.43	0.75	0.315	0.43	1/4-20UNC	F05
1 1/2"~2"	2.76	0.55	0.97	0.374	0.62	5/16-18UNC	F07
2 1/2"~4"	4.02	1.75	3.07	0.669	1.10	1/2-13UNC	F10

Size 1/2"-2"

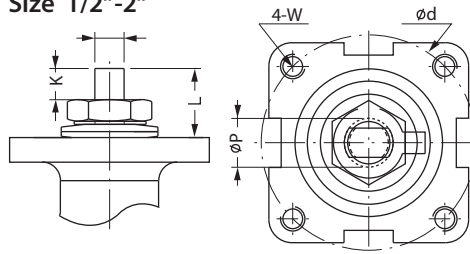

Size 2 1/2"- 4"

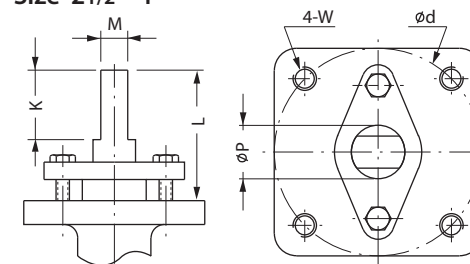

* Verify mounting dimensions before manufacturing mounting hardware
 * For 6" and larger size mounting dimensions, consult factory



Due to continuous development & improvement of our product range, we reserve the right to alter the dimensions & technical data included in this brochure.

Bill of Materials / Standard Bore Valves

No.	Name	Stainless Steel	Carbon Steel
1	Body	ASTM A351 CF8M	ASTM A216 WCB
2	Cap	ASTM A351 CF8M	ASTM A216 WCB
3	Stem*	SS316	SS316 / SS304
4	Packing Follower	SS304	SS304
5	Belleville Washer	SS301	SS301
6	Lock Washer	SS304	SS304
7	Ball	SS316	SS316 / SS304
8	Seat	TFM	TFM
9	Gasket	RPTFE / Graphite	RPTFE / Graphite
10	Stem Packing	TFM / Graphite	TFM / Graphite
11	Packing Protector	50%PTFE+SS316	50%PTFE+SS316
12	Thrust Washer	25%Carbon+TFM	25%Carbon+TFM
13	Anti-Static	SS304	SS304
14	Valve Stop	SS304	SS304
15	Handle	SS304	SS304
16	Locking Device	SS304	SS304
17	Handle Sleeve	Plastic	Plastic
18	Thin Nut	SS304	SS304
19	Bolt	SS304	Carbon Steel
20	O-Ring	Viton	Viton

1/2"-2" SF150/SF300 Exploded View

**Repair Kits
Soft Parts
Item # 8, 9,
10, 11, 12, 20**

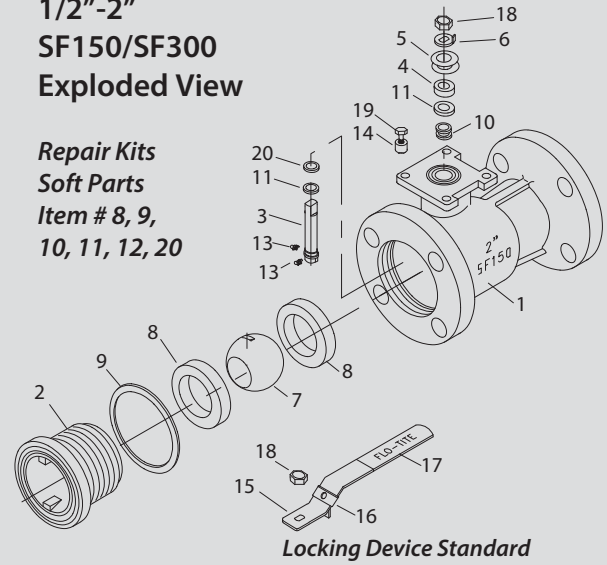

Locking Device Standard
New 2PC body design also available
Consult factory. Models RF15/RF30

Bill of Materials

No.	Name	Stainless Steel	Carbon Steel
1	Body	ASTM A351 CF8M	ASTM A216 WCB
2	Cap	ASTM A351 CF8M	ASTM A216 WCB
3	Stem*	SS316	SS316 / SS304
4	Packing Gland	ASTM A351 CF8	ASTM A351 CF8
5	Belleville Follower	SS304	SS304
6	Ball	SS316	SS316 / SS304
7	Seat	TFM	TFM
8	Stem Packing	TFM / Graphite	TFM / Graphite
9	Packing Protector	50%PTFE+SS316	50%PTFE+SS316
10	Gasket	RPTFE / Graphite	RPTFE / Graphite
11	Thrust Washer	25%Carbon+TFM	25%Carbon+TFM
12	O-Ring	Viton	Viton
13	Anti-Static	SS304	SS304
14	Travel Stopper	SS304	Steel
15	Snap Ring	Plated Steel	Plated Steel
16	Handle	Ductile Iron	Ductile Iron
17	Gland Bolt	SS304	Steel
18	Stop Housing	SS304	SS304
19	Housing Bolt	SS304	SS304
20	Set Screw	Steel	Steel

* Stem Optional Material 17-4PH

3"-12" SF150/SF300 Exploded View

**Repair Kits
Soft Parts
Item # 7, 8,
9, 10, 11, 12**

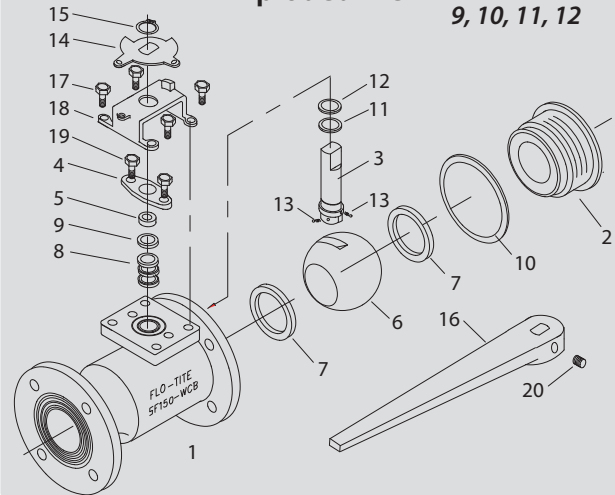

Optional live-loaded packing with belleville springs

Pressure Temperature Rating

These ratings are conservative guide for general service. Previous experience in process or new development may permit applications at ratings above those shown.

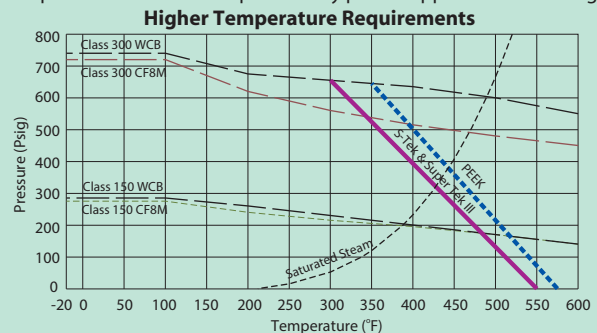
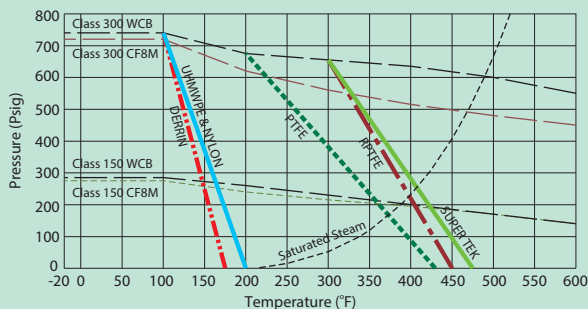

Saturated steam services above 150 psi use either Super Tek III or S-Tek. Saturated steam services above 250 psig use metal seats.
Metal Seated Ball Valve will take full ANSI body metal material ratings.

Dimensions - Reduced Bore

Technical Submittal

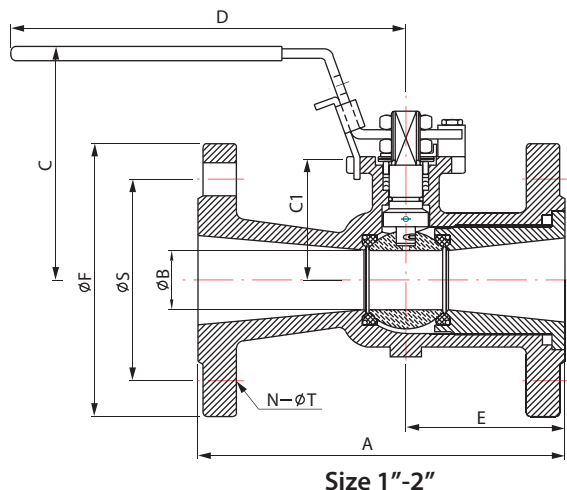

Size 1"-2"

SF150/SF300 Series

New 2 pc body design - RF15 Consult Factory

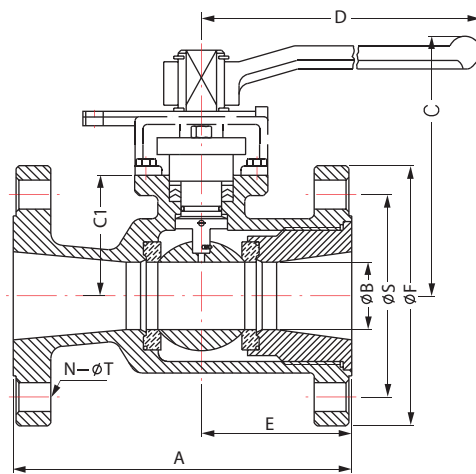

Size 2 1/2"- 12"

Model SF150 - ANSI Class 150

Size	A	B	C	C1	D	E	F	N	S	T	Cv	Torque in-lb	Est. Weight Lbs
1"	5.00	0.79	2.91	1.67	6.50	2.0	4.25	4	3.13	0.63	33	95	7
1 1/2"	6.50	1.26	3.62	2.20	7.87	2.17	5.00	4	3.88	0.63	85	252	12
2"	7.00	1.50	4.20	2.61	10.4	2.56	6.00	4	4.75	0.75	160	284	17
3"	8.00	2.56	6.22	3.78	15.4	3.0	7.50	4	6.00	0.75	340	651	38
4"	9.00	3.00	6.38	4.69	15.4	3.35	9.00	8	7.50	0.75	800	840	55
6"	10.5	4.00	.52	4.33	15.4	4.61	11.0	8	9.50	0.87	1090	1785	80
8"	11.5	5.98	10.1	6.85	25.6	5.85	13.5	8	11.75	0.87	2300	4830	191
10"	13.0	7.87	11.6	7.62	37.4	6.85	16.0	12	14.25	1.00	4000	10395	315
12"	14.0	9.84	12.8	8.92	38.0	7.00	19.0	12	17.0	1.00	7700	17850	518

Model SF300 - ANSI Class 300

Size	A	B	C	C1	D	E	F	N	S	T	Cv	Torque in-lb	Est. Weight Lbs
1"	6.50	0.79	2.91	1.67	6.50	2.18	4.88	4	3.50	0.75	33	100	9
1 1/2"	7.50	1.26	3.62	2.20	7.87	2.60	6.14	4	4.50	0.87	85	265	18
2"	8.50	1.50	4.13	2.61	10.4	2.92	6.50	8	5.00	0.75	160	298	25
3"	11.14	2.24	6.77	3.78	15.4	3.75	8.27	8	6.62	0.87	340	684	56
4"	12.0	3.15	7.68	4.69	15.4	3.86	10.0	8	7.87	0.87	800	882	75
6"	15.87	3.94	7.52	4.33	15.4	4.61	12.5	12	10.63	0.87	1090	1874	133
8"	16.5	5.91	10.1	6.85	25.6	5.85	15.0	12	13.0	1.00	2300	5072	303
10"	18.0	7.87	11.6	7.62	37.4	6.85	17.5	16	15.25	1.14	4000	10915	464
12"	19.75	9.53	13.7	8.92	38.0	7.00	20.5	16	17.75	1.25	7700	18743	818

Mounting Dimensions (SF150/SF300)

Size	d	K	L	M	P	W	ISO
1"	1.65	0.43	0.59	0.250	0.37	#10-24UNC	F04
1 1/2"	1.97	0.43	0.75	0.315	0.43	1/4-20UNC	F05
2"	2.76	0.55	0.91	0.374	0.62	5/16-18UNC	F07
3"	4.02	1.31	2.59	0.669	1.10	1/2-13UNC	F10
4",6"	4.02	1.75	3.07	0.669	1.10	1/2-13UNC	F10
8",10"	4.92	1.65	3.58	1.024	1.71	1/2-13UNC	F12
12"	5.51	2.13	3.86	1.378	1.97	5/8-11UNC	F14

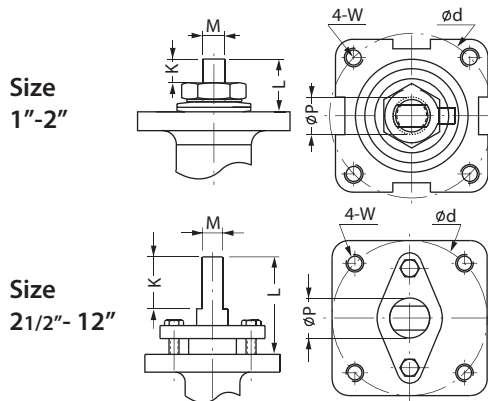

* Verify mounting dimensions before manufacturing mounting hardware

Unique Design Feature

Tamper Proof Locking Device Standard

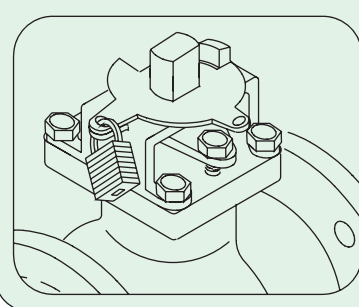

Valve topworks incorporates a tamper proof locking device, locks in open or closed positions. When valve stop housing is removed, four bolts remain to mount actuator bracket. Size: 2 1/2"-8"

Pressure Relieving & Equalizing Seat Design

Specially designed seats allow equalization of pressure in the ball cavity which reduces operating torque and increases seat life.



Ball Design Added Safety Feature

All balls are provided with a 1/8" hole drilled into the stem slot of each ball to prevent excessive pressure build up in the cavity from trapped liquid when the valve is in the open position.

Due to continuous development & improvement of our product range, we reserve the right to alter the dimensions & technical data included in this brochure.

DATASHEET PROVIDED COURTESY OF ACCURATE VALVE - ILLINOIS, USA - WWW.ACCURATEVALVE.COM - PH: +1 (708) 588 - 1433

High-Tech Design Features

Flo-Tite's Van Guard Stem Sealing System, designed to minimize fugitive emissions. Increases safety and provide an immediate ball valve solution to the newer EPA performance requirements, for valves meeting with a leak rate of 500ppm.

Flo-Tite's Van Guard Seal, state of the art stem sealing system. Incorporating a triple set of valve stem seals. This unique system eliminates the possibility of valve stem leaks in most all media applications.

STAGE I - FRONT LINE

Stage I provides a front line defense against leakage. The blow-out proof stem shoulder has a 45 degree bell shaped slope. The bell shaped design offers more sealing surface, effectively blocking all leak paths during rotation. The wedging action of the portion of the stem is far superior to the common small flat stem shoulder design.

STAGE II - GUIDE-SEAL

The O-ring originated early in valve design and has been a proven performer in high cycle applications. Its basic function reduces the potential of machining imperfections and provides a low torque flexible seal. This center guide also helps to maintain a perfect stem alignment, by eliminating side loading stress which can cause stem leaks.

STAGE III - LIVE-SEAL

Live-seal is considered the intellectual component and the workhorse of Flo-Tite's Van Guard stem sealing system. Working in unison with stages I and II, stage III calls upon the use of V-Ring packing sets which expand sideways as they are compressed and pressurized blocking all air pockets. The Van-Guard stem system is energized by disk or coil springs which continuously adjusts packing compression to compensate for wear, pressure or temperature changes.

Whether your service involves volatile organic compounds, volatile hazardous chemicals, or air pollutants, Flo-Tite's ball valves are by design dependable, long lasting and fully maintainable. Flo-Tite has various valve solutions and designs that provide end-users freedom of choice for the toughest requirements imposed by the industry and by international standards.

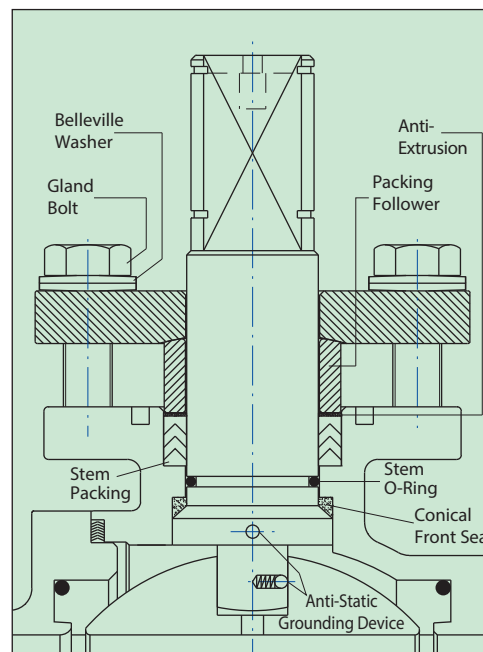
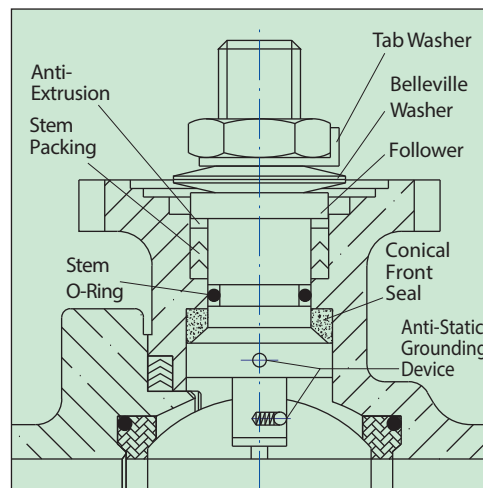

Flex-Load Energized Seat Design

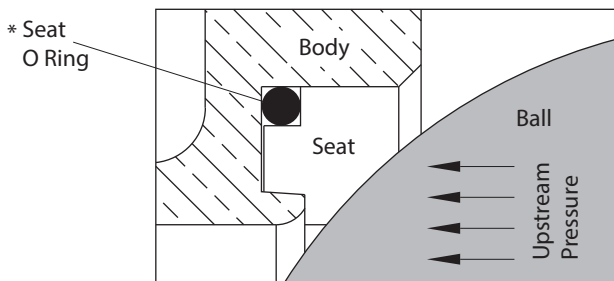

Viton O Rings are inserted behind valve seats. The O Ring exerts only a minimum amount of pressure on the seats that in turn helps seal on both upstream and downstream sides of the ball. Also, helps provide additional seat memory.

Ideal for high cycle, very low pressure & vacuum service applications.

* Standard offered with Viton material, consult factory if other material is required.

Flanged Valves with Media Containment Caps

The I-SO-Mount platform is ideal for the addition of our secondary containment units. Flo-Tite's media containment cap offers in-line maintenance for stem repair, protection for high temperature service, fugitive emission monitoring for early leak detection, positive displacement. It also can be used as a high-tech stem extension. See Tech Bulletin Page 140.

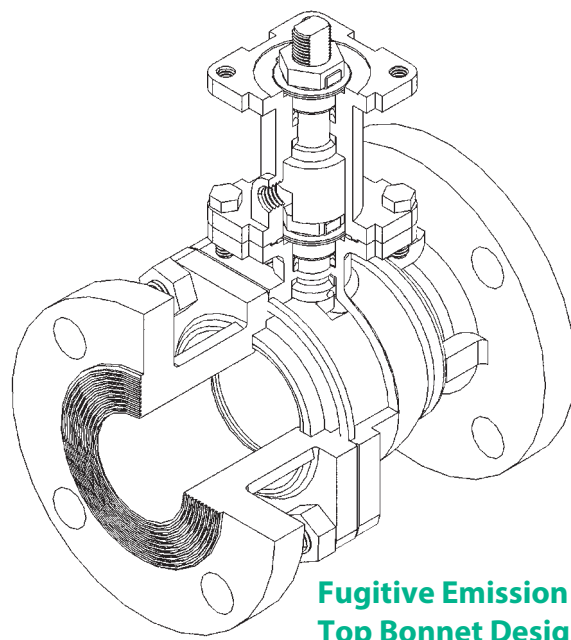

Fugitive Emission Top Bonnet Design

Product Identification Code for Complete Valve Model Numbers

Model	Body Material		Valve - Soft Parts						Operator	Size				
	Material	SS	Seat	Stem Seals	Body Seal	O - Rings	inch	mm						
Flanged End Full Bore F150 F300 F600	316SS	SS	TFM	F	TFM	F	TFM	F	VITON	V	Lever Locking	L	1/2	15
	WCB	CS	CTFM	Y	CTFM	Y	CTFM	Y	EPDM	E	Oval Locking	O	3/4	20
	Alloy 20	A2	PTFE	T	RTFM	X	PTFE	T	PTFE	T	Gear	G	1	25
Flanged End Standard Bore RF15 SF150 RF30 SF300 SF600	Duplex	DP	RPTFE	R	PTFE	T	RPTFE	R	BUNA	B	Deadman	S	11/4	32
			50/50	S	RPTFE	R	50/50	S	NONE	N	Actuator	A	11/2	40
			UHMWPE	U	50/50	S	UHMWPE	U			Bare Stem	N	2	50
		PEEK	P	UHMWPE	U	PEEK	P			Special	X	2/12	65	
		Cavity Filled	C	PEEK	P	Graphite	G					3	80	
		Metal	M	Graphite	G	Kel-F	K					4	100	
		Kel-F	K									5	125	
												6	150	
												8	200	
												10	250	
												12	300	

Material Identification

Flo-Tite's marking system follows MSS SP-25-1998 guidelines. In addition to the cast body information, we have decided to add metal name plates that identify all valve soft parts.

Valve users worldwide will be able to contact Flo-Tite quickly for any installation or service requirements as the company website address will be on all valves.

Model # F150				
TRIM	F	F	G	V
Special				
www.flotite.com				

Ordering Information

when placing an order or requesting a quotation, please provide as many details on the application as possible such as media type, temperature, pressure, pipe size and etc.

Ordering Examples by Part Numbers

Flanged Full	316SS	TFM	Graphite	TFM	Viton	LEVER	2"	3/8" GAUGE Taps
Model	Body Material	Seat	Stem Seal	Body Seal	O-rings	Operator	Size	Special Feature
F150	SS	- F	G	F	V	- L	- 50	- G1

Optional - Special Design Valves

Flanged Valves with Cryogenic Extension

Flo-Tite offers cryogenic flanged valves. See Tech Bulletin page 138.



Vacuum Service Suitable to 20 Micron

Specially cleaned and lubricated valves can handle services of 10⁻³ mm of Hg (1 micron)

Flanged Valve with Fusible Link

Flo-Tite offers flanged valve with fusible link. See Tech Bulletin page 126.



Flanged Valve in Control Valve Service

Flo-Tite offers modulating V-port control valves. The V-ball is characterized to meet all custom flow requirements. See Tech Bulletin page 120.



V-ports 15, 30, 60, 90 deg V & slotted balls.

Flo-Tite Ball Valves, serving multi-national end users in a wide range of applications in many industries including:

- Chemical & petrochemical
- Power generation plants
- Ship building industries
- Fiber industries
- Food industries
- LNG, HRSG industries
- Oil refinery industries
- Desalination industries
- Steel & iron industries
- Pulp & paper plants
- Coal & mining industries
- Higher Pressure HVAC Applications

Specific descriptions, dimensions and construction details illustrated may vary slightly from this bulletin. They are for general use only. We reserve the right to revise or modify product design without prior notice.



Flo-Tite, Inc.
4815 W 5th St.
Lumberton, NC 28358

P.O. Box 1293
Lumberton, NC 28359
Website: www.flotite.com

Tel: (910) 738-8904
Fax: (910) 738-9112
E-mail: flotite@flotite.com

DATASHEET PROVIDED COURTESY OF ACCURATE VALVE - ILLINOIS, USA - WWW.ACCURATEVALVE.COM - PH: +1 (708) 588 - 1433