



3 PC Standard Port Design

PRO-MAX SERIES



Standard Bore

Stainless Steel
NPT - 361-SS-RGG-L
SW - 362-SS-RGG-L

Carbon Steel
NPT - 361-CS-RGG-L
SW - 362-CS-RGG-L

(OPTIONAL) Full Bore

Stainless Steel
NPT - 363-SS-RGG-L
SW - 364-SS-RGG-L

Carbon Steel
NPT - 363-CS-RGG-L
SW - 364-CS-RGG-L

Valve Features

- **3-Piece Body. Standard Port Design**
- **Fire Safe API 607**
- **1/2" to 2" Sizes**
- **Threaded, Socket-Weld Ends**
- **Body : CF8M / WCB**

Full Port Design Available Consult Factory

- **RTFE Seats or TFM**
- **Pressure Rating:**
 1/2" - 1 1/4" 2000 psi
 1 1/2" - 2" 1500 psi
 150 SWP

Design Advantages

- **ISO 5211 Mounting Pad - Provides for precise shaft alignment**
- **Improved Seat material - Extends cycle life and reduces torque**
- **Blowout Proof Stem**

- **Fire Safe to API 607 sixth edition**
- **Anti-Static Ground**
- **Fully Contained Body Bolts**
- **Locking Device Standard**
- **Live-Loaded Stems**

Applicable Standards

- **Body Wall Thickness - ASME B16.34**
- **NPT and Socket Weld Ends - ASME B 16.11**
- **Basic Dimensions - ASME B 16.34**

- **Testing Standards - ASME B 16.34 API 598**
- **NACE - MR-0175**
- **All Valves Are CE Stamped**

Designed for Fire Safe Applications at Economical Prices

Design and Technical Data

Materials of Construction

Item	Parts	Stainless Steel	Carbon Steel
1	Body	A351 CF8M	A216 WCB
2	Ball	A351 CF8M	A351 CF8M
3	Stem	SS316	SS316
4	Cap *	A351 CF8M	A216 WCB
5	Gasket	Graphite	Graphite
6	Seat	RPTFE	RPTFE
7a	Thrust Washer	RPTFE	RPTFE
7b	Thrust Washer	Graphite	Graphite
8a	Stem Packing	RPTFE	RPTFE
8b	Stem Packing	Graphite	Graphite
9	Follower	SS304	SS304
10	Handle	SS304	SS304
11	Handle Cover	Plastic	Plastic
12	Thin Nut	SS304	SS304
13	Disc Washer	SS301	SS301
14	Lock Washer	SS304	SS304
15	Locking Pad	SS304	SS304
16	Set Screw	SS304	SS304
17	Bolt	A193 B8M	A193 B7M
18	Nut	A194 8M	A194 2HM
19	Anti-Static	SS316	SS316

* welding end cap material A351 CF3M

PRO-MAX SERIES

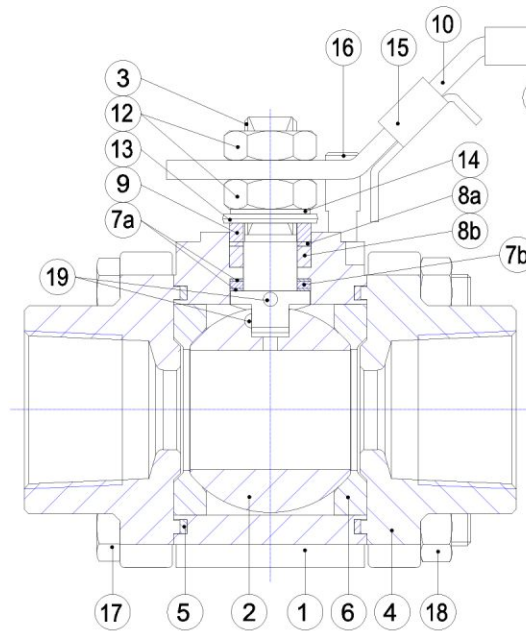

Steam Rating: 150 PSI WSP
Vacuum service to 20 microns

310 Series valves comply with MSS-SP 72.

All valves are tested in accordance with MSS-SP 72.

Threaded End Connections meet ASME/ANSI B1.20.1 NPT.

Socket Weld End Connections meet ASME/ANSI B16.11

310 Series Valves carried CE Marking

Pressure/Temperature Chart

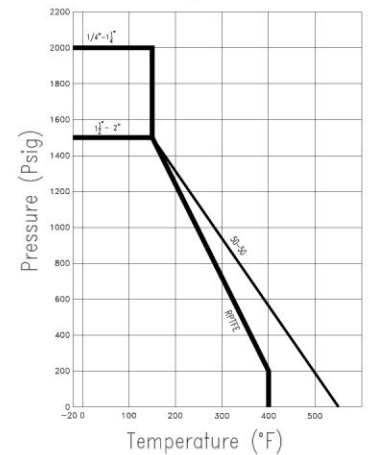

Models 310 Series

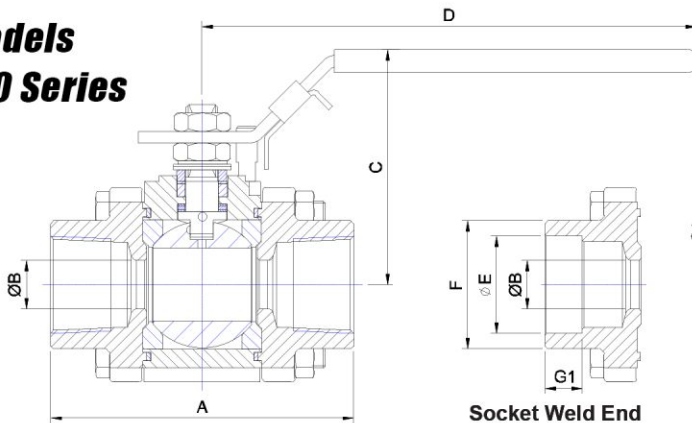

Socket Weld End

300 Series Mounting Dimensions

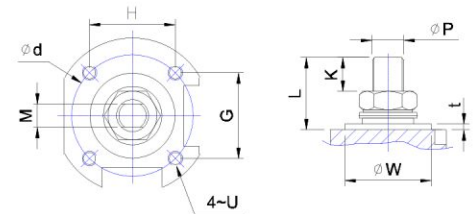

IMPORTANT: Mounting Dimensions Are for Estimating Purpose Only. Consult Factory Before Manufacturing Bracket.

Dimensions and Weights

SIZE	A	B	C	C1	D	E	F	G1	t	W	d	G	H	M	P	K	L	U	Cv	Torque in-lb	ISO Pattern	Weight Lbs
1/4"	2.55	0.39	2.47	1.13	5.23	0.56	1.16	0.39	0.02	0.98	1.42	1.00	1.00	0.250	0.37	0.26	0.34	#10-24UNC	8	48	F03	1.58
3/8"	2.55	0.39	2.47	1.13	5.23	0.69	1.16	0.39	0.02	0.98	1.42	1.00	1.00	0.250	0.37	0.26	0.34	#10-24UNC	8	48	F03	1.54
1/2"	2.55	0.39	2.47	1.13	5.23	0.85	1.16	0.39	0.02	0.98	1.42	1.00	1.00	0.250	0.37	0.26	0.34	#10-24UNC	8	48	F03	1.5
3/4"	2.85	0.59	2.72	1.14	5.23	1.07	1.18	0.51	0.08	0.98	1.42	1.00	1.00	0.250	0.37	0.31	0.65	#10-24UNC	13	65	F03	2.3
1"	3.36	0.79	2.89	1.30	5.23	1.33	1.42	0.51	0.08	0.98	1.42	1.00	1.00	0.250	0.37	0.35	0.70	#10-24UNC	33	93	F03	3.4
1 1/4"	4.15	1.00	3.22	1.42	6.76	1.69	1.75	0.51	0.08	1.18	1.65	1.17	1.17	0.315	0.44	0.47	1.00	#10-24UNC	46	139	F04	5.1
1 1/2"	4.37	1.26	3.42	1.57	6.76	1.92	2.13	0.51	0.08	1.18	1.65	1.17	1.17	0.315	0.44	0.46	1.02	#10-24UNC	85	195	F04	6.7
2"	5.01	1.50	3.84	1.86	8.04	2.41	2.36	0.63	0.09	1.38	1.97	1.39	1.39	0.374	0.56	0.59	1.25	1/4-20UNC	160	325	F05	11.6



Flo-Tite, Inc.
4815 West 5th Street
Lumberton, NC 28358

P.O. Box 1293
Lumberton, NC 28359
Website: www.flotite.com

Tel: 910.738.8904
Fax: 910.738.9112
E-mail: flotite@flotite.com

DATASHEET PROVIDED COURTESY OF ACCURATE VALVE - ILLINOIS, USA - WWW.ACCURATEVALVE.COM - PH: +1 (708) 588 - 1433