



TITAN FLOW CONTROL, INC.

## CHECKVALVE ♦ LUG STYLE ♦ DUAL DISC

## ASME CLASS 150 ♦ CARBON AND STAINLESS STEEL

**MODELS: CV 42L-CS**

(CARBON STEEL - LUG)

**CV 42L-SS**

(STAINLESS STEEL - LUG)

SIZES: 2" ~ 24"

LUG STYLES ARE BLIND TAPPED AS STANDARD

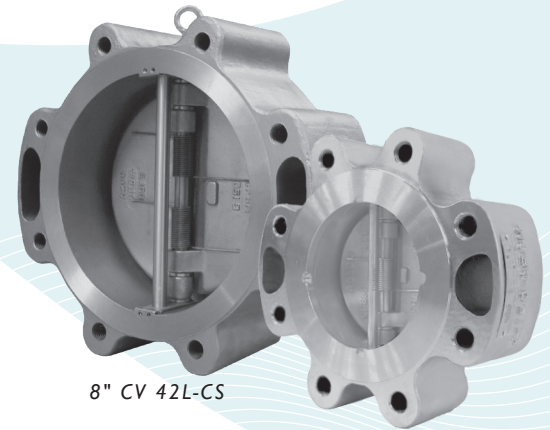

8" CV 42L-CS

4" CV 42L-SS

2" ~ 5" HAVE RETAINER-RING DESIGN.

6" ~ 24" USE RETAINER-CAP DESIGN.

## FEATURES

- ♦ **MINIMAL HEAD LOSS**  
CONTOUR OF BODY PROVIDES A SHORT AND STRAIGHT FLOW PATH THAT GENERATES VERY LITTLE TURBULENCE. ADDITIONALLY, THE SPRING-LOADED DISCS ARE DESIGNED WITH VERY LOW CRACKING PRESSURE WHICH REDUCES THE AMOUNT OF ENERGY REQUIRED TO OPEN THE VALVE.
- ♦ **QUICK CLOSURE TO REDUCE WATER HAMMER**  
SHUT-OFF IS ACHIEVED VIA THE FULLY AUTOMATIC, SPRING-ASSISTED DISCS THAT CLOSE NEAR ZERO FLOW VELOCITY. THE LIGHTWEIGHT, SPLIT DISC DESIGN CREATES A POSITIVE SHUTOFF PRIOR TO FLOW REVERSAL AND HELPS TO KEEP SLAMMING AND SURGES TO A MINIMUM.
- ♦ **DESIGNED FOR LONG SERVICE LIFE**  
THE SPRING AND DISCS ARE DESIGNED TO ALLOW THE DISCS TO LIFT LINEARLY BEFORE PIVOTING TO AVOID THE DISC HEAL FROM SCRUBBING THE SEALING SURFACE. ALSO, DISCS ARE EQUIPPED WITH CAST-IN SHOCK BUMPERS THAT HELP TO REDUCE WEAR AND TEAR ON INTERNAL COMPONENTS.
- ♦ **FUGITIVE EMISSION DESIGN**  
THE RETAINER-LESS BODY DESIGN ELIMINATES POTENTIAL LEAK PATHS TO THE ENVIRONMENT SO THERE ARE NO BODY EMISSIONS.
- ♦ **RESILIENT AND METAL SEATS**  
BOARD, LAPPED SEALING SURFACE (METAL) MEETS OR EXCEEDS API 598 TEST REQUIREMENTS. RESILIENT SEATS (VITON/BUNA) ENSURE A BUBBLE TIGHT SEAL.

## TECHNICAL

PRESSURE/TEMPERATURE RATING  
CS - ASTM A216 GR. WCB - CLASS 150

WOG (Non-shock): 285 PSI @ 100 °F

PRESSURE/TEMPERATURE RATING  
SS - ASTM A351 GR. CF8M - CLASS 150

WOG (Non-shock): 275 PSI @ 100 °F

SEAT MATERIAL  
TEMPERATURE RANGEVITON: -40 ~ 400 °F  
BUNA-N: -20 ~ 250 °FSPRING MATERIAL  
TEMPERATURE MAXIMUM

INCONEL X-750: 1000 °F

*The above listed temperatures are theoretical and may vary during actual operating conditions.*

## APPLICATIONS

**MARKETS:** WATER & WASTEWATER, PULP & PAPER, CHEMICAL & PETROCHEMICAL, POWER, PETROLEUM AND OIL & GAS**BUNA-N PROPERTIES:** MOST WIDELY USED ELASTOMER. GOOD FOR MOST PETROLEUM OILS AND FLUIDS, SILICONE GREASES AND OILS, AND COLD WATER. EXCELLENT COMPRESSION SET, TEAR, AND ABRASION RESISTANCE. POOR WEATHER RESISTANCE AND MODERATE HEAT RESISTANCE. NOT RECOMMENDED FOR SEVERE OZONE-RESISTANT APPLICATIONS.**VITON PROPERTIES:** OFFERS A BROAD RANGE OF CHEMICAL RESISTANCE AND EXCELLENT HEAT RESISTANCE. GOOD MECHANICAL PROPERTIES AND COMPRESSION SET RESISTANCE. OFTEN USED IN APPLICATIONS WHERE NOTHING ELSE WILL WORK. FAIR LOW TEMPERATURE RESISTANCE AND LIMITED HOT-WATER RESISTANCE AND SHRINKAGE.*The above data represents common market and service applications. No representation or guarantee, expressed or implied, is given due to the numerous variations of concentrations, temperatures and flow conditions that may occur during actual service.*

**TITAN FLOW CONTROL, INC.**  
**YOUR PIPELINE TO THE FUTURE!**

Tel: 910-735-0000 ♦ Fax: 910-738-3848 ♦ titan@titanfci.com ♦ www.titanfci.com  
 290 Corporate Drive ♦ PO Box 7408 ♦ Lumberton, NC 28358



**TITAN FLOW CONTROL, Inc.**

290 Corporate Drive  
Lumberton, NC 28358  
Tel: 910.735.0000

E-mail: titan@titanfci.com  
Web: www.titanfci.com  
Fax: 910.738.3848

**CHECK VALVE • LUG • DUAL DISC**

Lug-Style  
**CV 42L-CS (Carbon Steel)**

ASME Class  
150

**BILL OF MATERIALS (1)**

No.	PART	CV42L-CS	CV42L-SS
1	Body	Carbon Steel A216 Gr.WCB	Stainless Steel A351 Gr. CF8M
2	Seat	Metal/Viton/Buna-N (4)	Metal or Viton(4)
3	Disc (2)	Stainless Steel A351 Gr. CF8M	Stainless Steel A351 Gr. CF8M
4	Spring (2)	Inconel X-750	Inconel X-750
5	Shaft/Stop Pin	Stainless Steel A276 Gr. 316	Stainless Steel A276 Gr. 316
6	Cap	Carbon Steel ASTMA105	Stainless Steel A351 Gr. CF8M
7	Eye Bolt (3)	Carbon Steel	Carbon Steel

- Bill of Materials represents standard materials. Equivalent or better materials may be substituted at the manufacturer's discretion.
- Denotes recommended spare parts.
- Part #7, Eye Bolt, is only on Sizes 8" and up.
- Metal seat is stainless steel.

**Additional Design & Technical Notes:**

- The CV42L has a fugitive emission design. The retainer design body design eliminates potential leak paths to the environment so there are no body emissions.

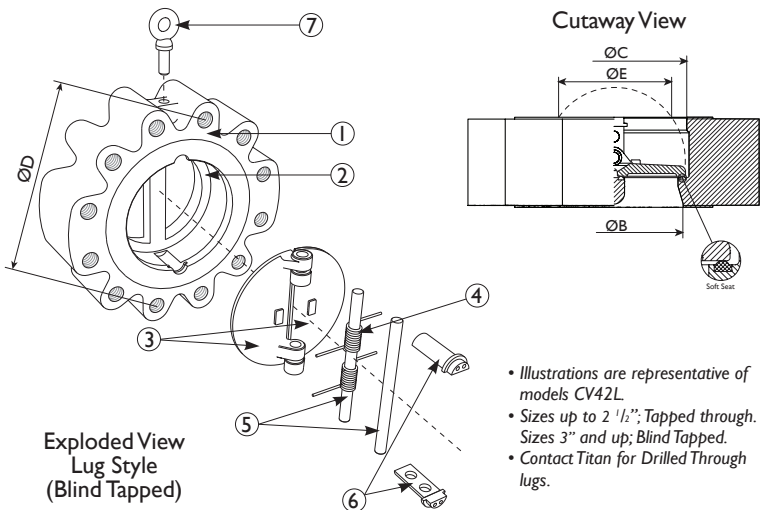

- Illustrations are representative of models CV42L.
- Sizes up to 2 1/2"; Tapped through. Sizes 3" and up; Blind Tapped.
- Contact Titan for Drilled Through lugs.

**DIMENSIONS AND PERFORMANCE DATA (1)**

SIZE	in	2	2 1/2	3	4	5	6	8	10	12	14	16	18	20	24
		mm	50	65	80	100	125	150	200	250	300	350	400	450	500
<b>A DIMENSION</b> FACE TO FACE (2)	in	2.38	2.62	2.88	2.88	3.38	3.88	5.00	5.75	7.12	7.25	7.50	8.00	8.62	8.75
	mm	60	67	73	73	86	99	127	146	181	184	191	203	219	222
<b>ØB DIMENSION</b> INLET DIAMETER	in	2.00	2.50	3.00	4.00	5.00	5.98	8.00	10.00	12.00	13.26	15.24	17.24	19.50	23.42
	mm	51	64	76	102	127	152	203	254	305	337	387	438	495	595
<b>ØC DIMENSION</b> OUTLET DIAMETER	in	2.16	2.67	3.23	4.25	5.12	6.50	8.66	10.63	12.60	13.78	15.75	17.24	19.50	23.42
	mm	55	68	82	108	130	165	220	270	320	350	400	438	495	595
<b>ØD DIMENSION</b> BOLT CIRCLE DIAMETER	in	4.75	5.5	6.0	7.5	8.5	9.5	11.75	14.25	17.0	18.75	21.25	22.75	25.0	29.5
	mm	121	140	152	191	216	241	298	362	432	476	540	578	635	749
<b>ØE DIMENSION</b> MINIMUM BORE DIAMETER(4)	in	.75	1.69	2.36	3.54	4.45	5.31	7.13	8.82	10.47	11.81	14.29	15.87	18.03	22.28
	mm	24	43	60	90	113	135	181	224	266	300	363	403	458	566
<b>NO. OF BOLTS</b>	qty	4	4	4	8	8	8	8	12	12	12	16	16	20	20
<b>BOLT SIZE</b>	in-UNC	5/8-11	5/8-11	5/8-11	5/8-11	3/4-10	3/4-10	3/4-10	7/8-9	7/8-9	1-8	1-8	1 1/8-8UN	1 1/8-8UN	1 1/8-8UN
<b>ASSEMBLED WEIGHT (Lug)</b>	lb	8.0	C/F	16.0	28.0	C/F	50.0	95.0	150.0	242.0	C/F	C/F	C/F	C/F	C/F
	kg	3.6	C/F	7.3	12.7	C/F	22.7	43.1	68.0	109.8	C/F	C/F	C/F	C/F	C/F
<b>Flow Coefficient</b>	C <sub>v</sub>	62	110	175	350	550	850	1500	2400	3700	5400	8250	10400	14200	23000
<b>Cracking Pressure (3)</b>	psi	≤ .25	≤ .25	≤ .25	≤ .25	≤ .25	≤ .25	≤ .25	≤ .25	≤ .25	≤ .25	≤ .25	≤ .25	≤ .25	≤ .25

- Dimensions and weights are for reference only. When required, request certified drawings.
- Face to face values have a tolerance of ±0.06 in (±0.20 mm) for sizes 10" and lower and a tolerance of ±0.12 in (±3.0 mm) for sizes 12" and larger.
- Cracking pressure is for horizontal installations only. For vertical installations, please consult factory.
- Minimum Bore Diameter indicates the minimum internal diameter of the adjacent pipe.

**PRESSURE - TEMPERATURE RATINGS (1)**

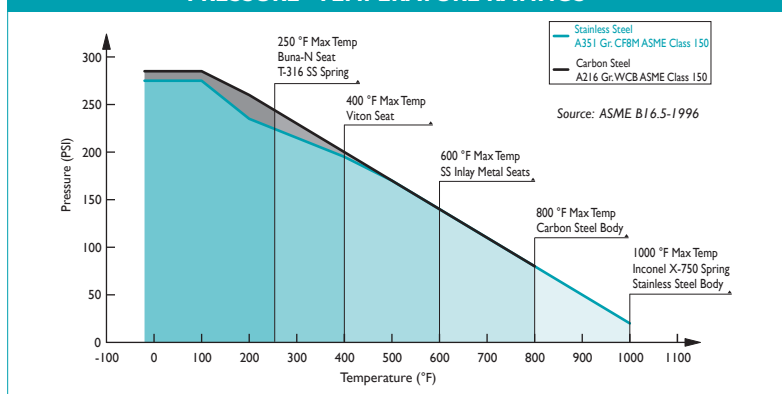

- The above chart displays the pressure-temperature ratings for the valve's body material per ASME B16.5-1996. Max temperature limits have been added for seat and spring materials.

**REFERENCED STANDARDS & CODES**

CODE	DESCRIPTION
AMSE/API 594	Valve Design and Manufacture
ASME 16.5	Flange Dimensions
ASME/API 594	Valve Face to Face Dimensions
API 598	Valve Inspection and Pressure Test

**PRESSURE - TEMPERATURE RATING**

Body Material	A216 Gr. WCB	A351 Gr. CF8M
WOG (Non-shock):	285 PSI @ 100 °F	275 PSI @ 100 °F

**SEAT AND SPRING TEMPERATURE RATING**

Seat Material	Range	Spring Material	Max
VITON:	-40 ~ 400 °F	INCONEL X-750:	1000 °F
BUNA-N:	-20 ~ 250 °F	T-316 SS:	450 °F

DATASHEET PROVIDED COURTESY OF ACCURATE VALVE - ILLINOIS, USA - WWW.ACCURATEVALVE.COM - PH: +1 (708) 588 - 1433