

OVC# GL800SW/TE

Socket Weld End & Threaded End
Forged Steel Globe Valve

Features

- Basic design: API 602
- Test: API 598
- Socket weld dimensions: ASME B16.11
- Screw end dimensions: ASME B1.20.1 (NPT)

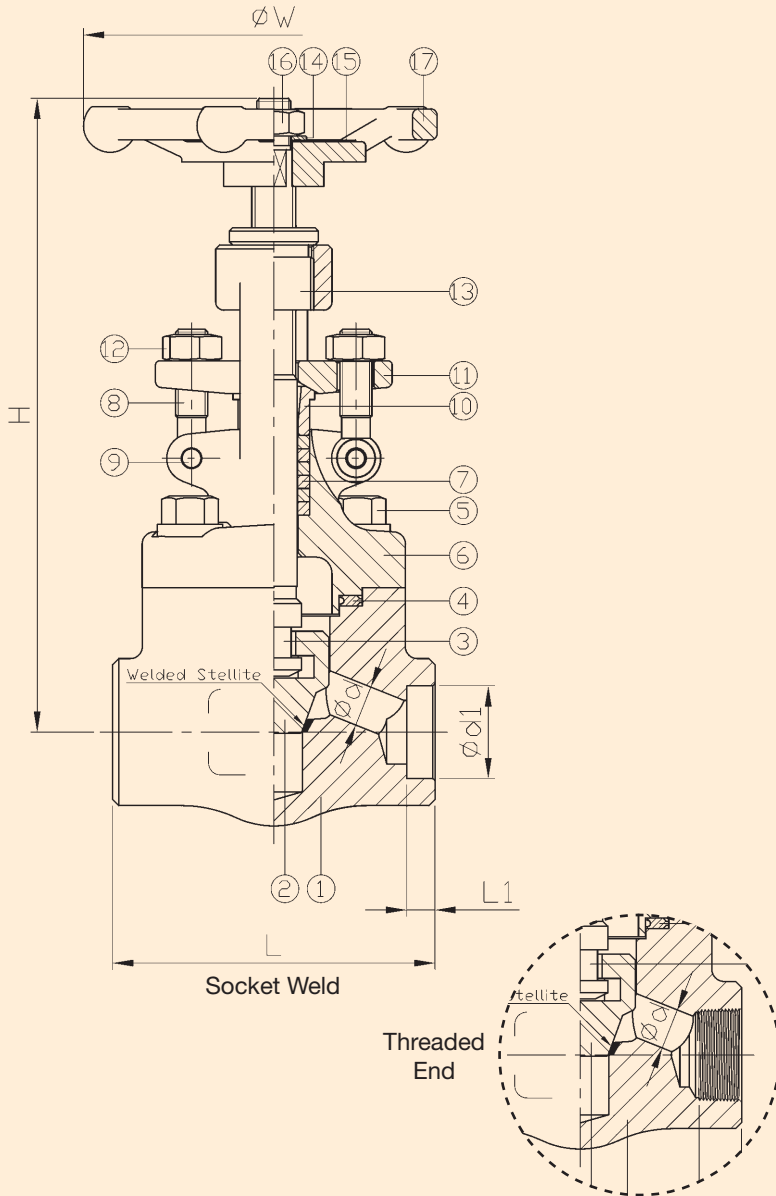

NO.	DESCRIPTION	MATERIAL
1	BODY	ASTM A105 + STELLITE
2	DISC	ASTM A276-420
3	STEM	ASTM A276-410
4	GASKET	304 + GRAPHITE
5	BOLT	ASTM A193-B7
6	BONNET	ASTM A105
7	PACKING	GRAPHITE
8	EYE BOLT	ASTM A 193-B7
9	PIN	ASTM A276-304
10	GLAND	ASTM A276-420
11	GLAND FLANGE	ASTM A216-WCB
12	NUT	ASTM A194-2H
13	STEM NUT	ASTM A276-410
14	WASHER	ASTM A276-410
15	NAMEPLATE	ALUMINUM
16	HANDWHEEL NUT	ASTM A108-1020
17	HANDWHEEL	ASTM A197

NPS	d	d1	L	L1	H OPEN	H CLOSE	W	Weight (lb)
1/4"	0.26	0.56	3.11	0.39	6.34	5.87	3.94	5.1
3/8"	0.37	0.69	3.11	0.39	6.34	5.87	3.94	5.1
1/2"	0.39	0.86	3.11	0.39	6.34	5.87	3.94	4.9
3/4"	0.51	1.07	3.62	0.51	6.34	5.87	3.94	5.3
1"	0.71	1.33	4.37	0.51	7.60	6.97	4.72	8.0
1-1/4"	0.91	1.68	4.72	0.51	9.06	8.35	6.30	13.2
1-1/2"	1.14	1.92	5.98	0.51	9.76	8.82	6.30	16.5
2"	1.42	2.41	6.77	0.63	11.10	10.16	8.66	24.8