

# 316L SS CHECK VALVE CSE-316L-V

## Features & Specifications

- » Precision machined ASTM 316L body, stem and disc
- » 25 Ra polished body and internals
- » Angle design for precision open and close
- » Suitable with viscous liquids
- » Stainless steel spring in both Tri-Clamp® and weld end designs
- » Standard VITON® seal ring, EPDM available option
- » Ideal for food, pharmaceutical, dairy and other sanitary industries
- » 150 PSI @ 250 °F (Approx. 121 °C)
- » ½"–6"



### Weld Ends

Size	A	B	C	D
1"	0.87	1.01	1.50	2.32
1½"	1.37	1.51	1.50	2.32
2"	1.87	2.01	1.50	2.32
2½"	2.37	2.51	1.50	2.32
3"	2.87	3.01	1.50	2.32
4"	3.82	4.13	1.73	1.97
6"	Call Factory for Details			

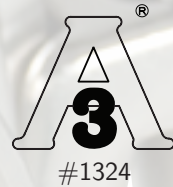
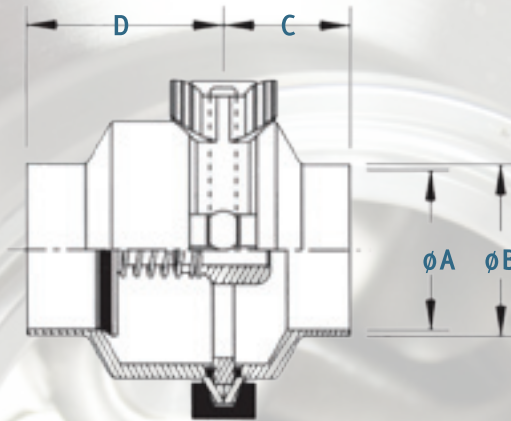

### Tri-Clamp® Ends

Size	A	B	C	D	E
½"	0.37	0.69	1.00	1.10	1.54
¾"	0.63	0.69	1.00	1.10	1.54
1"	0.87	1.71	1.99	1.65	2.32
1½"	1.37	1.71	1.99	1.65	2.32
2"	1.87	2.22	2.52	1.65	2.32
2½"	2.37	2.78	3.05	1.65	2.32
3"	2.87	3.29	3.58	1.65	2.32
4"	3.82	4.43	4.69	2.32	2.60
6"	Call Factory for Details				

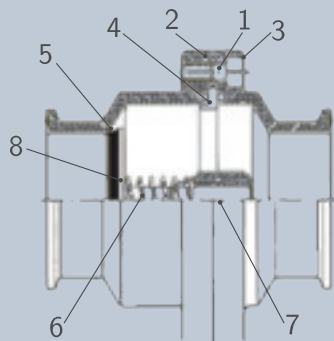
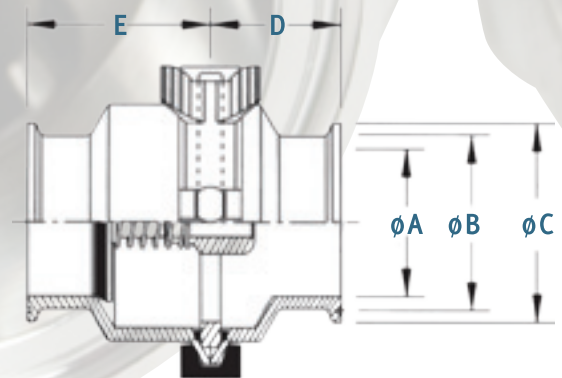

Item	Part (Qty)	Material
1	Short Body	316L SS
2	Long Body	316L SS
3	Screw (4" only)	316L SS
4	Body O-ring	EPDM
5	Seal Ring	VITON®
6	Spring	316L SS
7	Flow Support Plate	316L SS
8	Disc	316L SS