

# SERIES 19 SMART MODULATING ELECTRIC ACTUATOR



## Standard Features (All Sizes)

- **Compact:** Perfect for OEM and skid manufacturers
- **OLED Screen:** Displays input command, position status, alert conditions
- **Push Buttons:** Used to calibrate/adjust end positions, local controls
- **Multi-voltage:** 95 VAC to 265 VAC or 24 VAC/VDC
- **Motor:** Reversing, brushless DC motor
- **Gear Train:** Permanently lubricated steel gears
- **Corrosion Resistant Enclosure:** NEMA 4X ABS enclosure with stainless steel trim
- **ISO mounting configuration**
- **Electrical Connection:** NEMA 4X cable gland with two-meter cable
- **Position Indication:** Highly visible beacon position indicator
- **LED Fault:** BLUE
- **Manual Override:** Manually cycle valve via electroless nickel-plated hex key
- **Selectable Control Signal:** User can select 4-20 mA, 0-20 mA, 0-10 VDC, 2-10 VDC, or 1-5 VDC (size 20 is specifically a current control signal or a voltage control signal)
- **Reverse Acting:** User can select standard operation or reverse acting
- **Selectable Fail Position:** If control signal is lost, the unit can be calibrated to fail as is, fail open, or fail close
- **Transmitter:** Current or voltage transmitter (matching the control signal) is standard equipment
- **Alarm Contacts:** Dry contacts rated 0.1 Amp @ 250 VAC, 0.5 Amp @ 30 VDC for alarm status (over torque, as an example)
- **Space Heater:** Internally wired to limit condensation
- **CE Compliant:** All actuators are CE labeled and compliant
- **75% Duty Cycle:** Extended duty cycle is ideal for high cycling/modulating applications
- **Output Torque:** Series 19 electric actuators have an output torque range from 177 in-lbs to 973 in-lbs
- **QR Code:** Links to user manual; includes wiring schematic
- **Simple Wiring:** Wiring technique is the same for all voltage units
- **Local Controls:** Used with OLED and push buttons, a user can locally open or close units via password

## Specifications

<b>Sizes:</b>	S20, S50, S110
<b>Torque:</b>	177 in-lbs to 973 in-lbs
<b>Voltage:</b>	95 VAC to 265 VAC 1Ph 50/60 Hz
<b>Amp Draw:</b>	0.18 Amp for S20 0.24 Amp for S50 0.84 Amp for S110
<b>Electrical Connection:</b>	NEMA 4X cable gland with two-meter color-coded cable
<b>Max Ambient Temp:</b>	150° F
<b>Cycle Time:</b>	Per 90 degrees: 10 seconds
<b>Enclosure:</b>	NEMA 4X

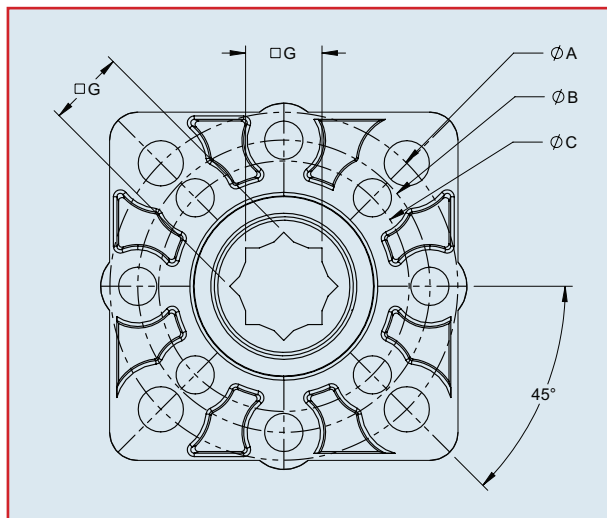

## Output Dimensions

Size	A	B	C	G
S20	F05 (M6)	F04 (M5)	F03 (M5)	14MM
S50	F07 (M8)	F05 (M6)	N/A	14MM
S110	F07 (M8)	F05 (M6)	N/A	17MM

## Weight (lbs)

Model	S20	S50	S110
Weight	1.7	1.7	4.8

## Engineering Data

Model	Torque (in-lbs)	95-265 VAC		24 VAC/VDC		Cycle time per 90 degrees [seconds]*
		Amp Draw	Duty Cycle	Amp Draw	Duty Cycle	
S20	177	0.18	75%	0.96	75%	10
S50	442	0.24	75%	1.20	75%	10
S110	973	0.84	75%	4.80	75%	10

Amp draw is considered locked rotor

\*Cycle times are approximate

Duty cycle shown for ambient temp [73° F]

# SERIES 19 SMART MODULATING ELECTRIC ACTUATOR

## Wiring Diagrams

### S20

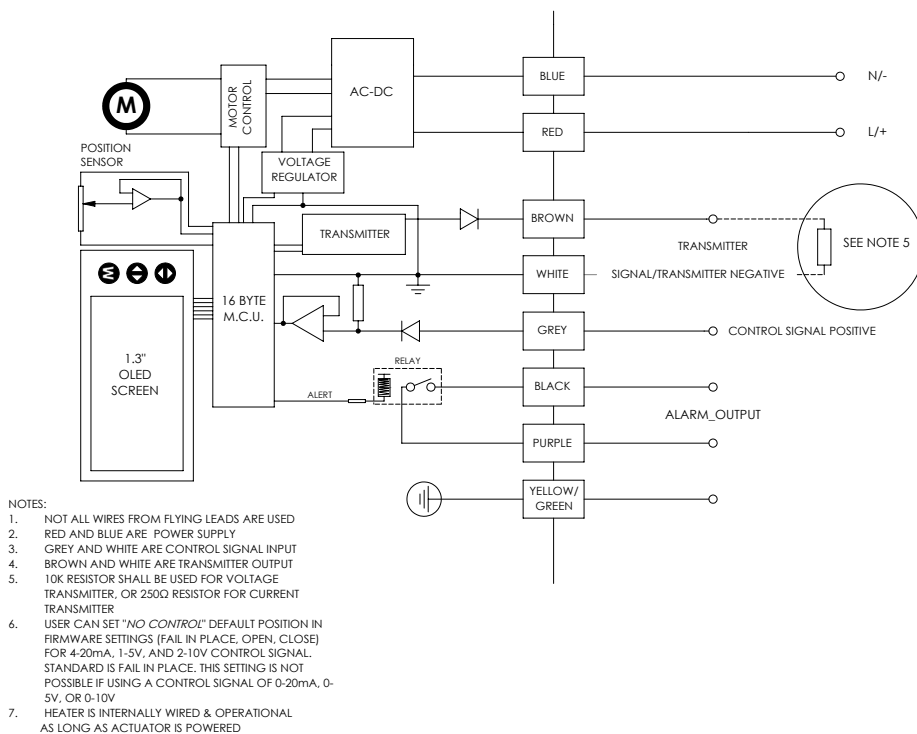

### S50-S110

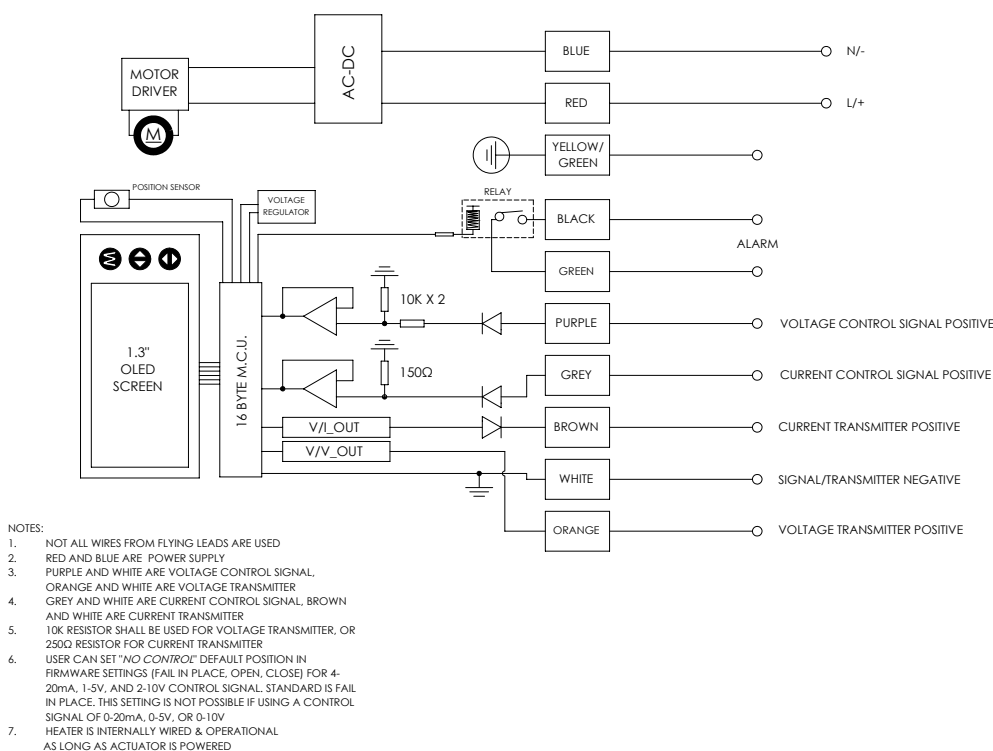

## Sample Specification

All Series 19 SAV smart modulating electric actuators shall have a brushless DC motor that accepts multiple voltages, permanently lubricated steel gears, NEMA 4X ABS enclosure with stainless steel trim, visual beacon indication, ISO 5211 valve mounting platform, manual override, and be CE compliant. Standard features shall include a heater, transmitter, field selection of various control signals, field selection of fail position (upon loss of command signal), one set of dry contacts for alarm reporting, LED indicator for alarm conditions, an OLED screen with push buttons, local controls, and a QR code that links to its user manual and wiring schematic.